

REMKOR METAL ENCLOSURES



REMKOR TECHNOLOGIES (PTY) LTD





SINGLE- AND DOUBLE LOCK ENCLOSURE



OPTIONAL EXTRA'S



ENCLOSURE WITH WINDOW



STAINLESS STEEL ENCLOSURE



IN-SITU GASKET TECHNOLOGY



MOUNTING BRACKETS



Remkor Technologies house a state-of the-art steel fabrication facility in Industrial Johannesburg - South Africa. As an ISO 9001 certified company, Remkor proudly assures their customer of the highest quality standard throughout the manufacturing process. Remkor have recently launched a range of IP55 and IP65 accredited Enclosures, available in Mild or Stainless Steel, to suit the markets every need.

Remkor Technologies specialize in the fabrication of high quality, durable industrial enclosures for the Electrical and Electronic markets ranging from standard wall mounted units to specialized floor standing units. All enclosures are available with optional extras such as an inner door, canopy, gland plate or a glass door. The in-house design department offers customized enclosures to suit every customer-specific application.

No matter the requirement – from CAD design to final shipping - we pride ourselves in our ability to offer an easy and affordable solution to our customers.

REMKOR - IP 65 ENCLOSURE DIMENSIONS (ALL SIZES IN MM)

CODE Without gland plate	CODE With gland plate	ENCLOSURE				GLASS DOOR Visual area		GLAND PLATE Opening	
		H	W	D	D*	H	W	W	D
RE 20		250	200	150	129	n/a	n/a	n/a	n/a
RE 30		350	250	170	147	n/a	n/a	n/a	n/a
RE 40	RG 40	450	300	220	197	330	130	240	160
RE 50	RG 50	550	400	220	197	430	230	340	160
RE 60	RG 60	650	450	270	247	530	280	390	210
RE 70	RG 70	750	550	270	247	630	380	490	210
RE 80	RG 80	850	600	270	247	750	460	540	210
RE 83	RG 83	850	600	330	289	750	460	540	270
RE 90	RG 90	950	700	270	247	830	530	640	210
RE 93	RG 93	950	700	330	289	830	530	640	270
RE 110	RG 110	1150	850	270	247	1030	680	790	210
RE 113	RG 113	1150	850	330	289	1030	680	790	270

*Depth to Door

Powder coating colour options available

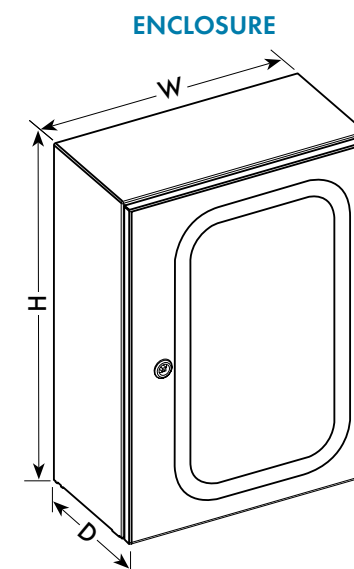

ENCLOSURE

CANOPY

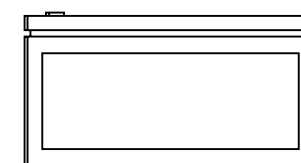
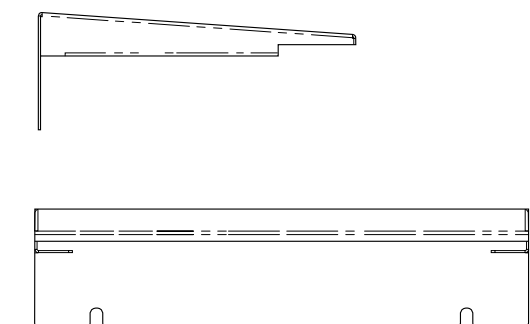

GLAND PLATE



*Remkor's world class production facility in
West Turffontein, Johannesburg.*



Your first choice in metal enclosures!



REMKOR TECHNOLOGIES (PTY) LTD

62 Third Street • West Turffontein • Johannesburg • South Africa
PO Box 39276 • Booyens • 2016 • South Africa

Tel: +27 11 433-4985

Fax: +27 11 433-4951

E-mail: sales@remkor.com

website: www.remkor.com